

300000AT Series

Open Frame Design

Designed for applications requiring a large center opening, the 300000AT series of positioning tables are ideal for back lighting, wafer positioning, part inspection and scanning applications. The linear bearings are constructed from two ball slide linear bearings which provide exceptionally smooth, flat, straight motion. Since there are two complete bearing assemblies for each axis, the table is not preloaded across the carriage.

All models are available in single or X-Y versions except the 310061AT, which is available only in an X-Y configuration.



Standard or Precision Grades

All models are available in both a standard or precision grade. The standard grade is equipped with a ground lead screw and composite nut, while the precision grade is equipped with a precision ground lead screw and composite nut.

Specifications

		310062AT	315081AT	315082AT	315101AT
Travel – inches (mm)		6 x 6 (150 x 150)	8 (200)	8 x 8 (200 x 200)	10 (250)
Positional Accuracy* – x 0.001 in (µm) Over Total Table Travel	Standard Grade	1.2 (30)	1.6 (40)	1.6 (40)	2.0 (50)
	Precision Grade	0.48 (12)	0.64 (16)	0.64 (16)	0.8 (20)
Positional Repeatability* – x 0.001 in (µm)	Standard Grade	±1 (±25)	±1 (±25)	±1 (±25)	±1 (±25)
	Precision Grade	±0.05 (±1.3)	±0.05 (±1.3)	±0.05 (±1.3)	±0.05 (±1.3)
Straight Line Accuracy* – x 0.001 in (µm) Over Total Table Travel	Standard Grade	3 (76)	4 (102)	4 (102)	5 (127)
	Precision Grade	1.2 (31)	1.6 (41)	1.6 (41)	2 (51)
Flatness Accuracy* – x 0.001 in (µm) Over Total Table Travel	Standard Grade	3 (76)	4 (102)	4 (102)	5 (127)
	Precision Grade	1.2 (31)	1.6 (41)	1.6 (41)	2 (51)
Max Screw Speed – rps	Standard Grade	15	15	15	15
	Precision Grade	25	25	25	25
Max Acceleration – in/sec ² (mm/sec ²)	Standard Grade	24 (600)	24 (600)	24 (600)	24 (600)
	Precision Grade	48 (1200)	48 (1200)	48 (1200)	48 (1200)
Duty Cycle – % of motion to dwell cycle	Standard Grade	50	50	50	50
	Precision Grade	75	75	75	75
Direct Loading** – lbs (kgf)	Normal	160 (72)	245 (111)	210 (95)	245 (111)
	Inverted	80 (36)	122 (56)	105 (47)	122 (56)
Axial Loading – lbs (kgf)	Standard Grade	25 (11,3)	25 (11,3)	25 (11,3)	25 (11,3)
	Precision Grade	55 (24,9)	55 (24,9)	55 (24,9)	55 (24,9)
Input Inertia*** – 10 ⁻³ oz-in-sec ² (10 ⁻⁶ kg-m-sec ²)		1.204 (0,87)	1.747 (1,26)	— —	1.747 (1,26)
Running Torque – oz-in (N-m)		15 (0,106)	15 (0,106)	15 (0,106)	15 (0,106)
Breakaway Torque – oz-in (N-m)		16.5 (0,117)	16.5 (0,117)	16.5 (0,117)	16.5 (0,117)
Drive Screw Efficiency—Standard & Precision Leadscrew – %		30	30	30	30
Coefficient of Linear Bearing Friction	Ball Slide	0.003	0.003	0.003	0.003
Table Weight - lbs (kgf)	Ball Slide	25 (11,4)	36 (16,4)	72 (32,8)	36 (16,4)
X-Y Squareness Arc Seconds	Standard	60	—	60	—
	Precision	30	—	30	—

* Measured over centerline of drive screw

** Refer to page B37 for moment load graphs

*** Based on 5 pitch (0.2 inch lead) leadscrew

Linear Open Frame Tables

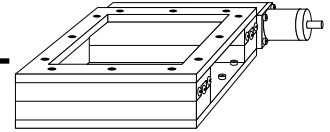

Wide Selection of Lead Screws

Available with a wide range of Daedal manufactured drive screws with leads in both Imperial and metric to match your resolution and speed requirements.

Quality Design in Imperial or Metric Mounting

Table housings are constructed of high quality aluminum alloy and are protected with a black anodized surface finish. The top and bottom mounting surfaces are precision machined to assure flatness, and all mounting holes are fitted with locking steel threaded inserts to prevent mounting bolts from working loose. The linear bearings are made of 440C stainless steel. The 6, 8 and 12 inch travel models are also available with metric mounting.

Options:

Motor Couplings

A wide range of coupling styles and bores are available to match your motor requirements. Bellows-style couplings are required for all precision grade tables and offer the lowest radial wind up, while the aluminum and stainless steel helix couplers offer good wind-up characteristics and high durability at a lower cost.

Motor Mount

The standard motor mount is designed for an industry standard NEMA 23 motor flange with shaft lengths of 0.65 to 0.85 inches. An optional NEMA 34 frame motor mount is available for all models except the 310062AT. These mounts accept motors with an industry standard NEMA 34 flange and shafts with lengths between 1.0 to 1.25 inches.

Limit and Home Switches

All models can be equipped with either mechanical reed or optical sensor-type limit and home switch assemblies. The limit switches provide a signal when the table is approaching its end of travel which is used to command the motor to stop. The Home sensor provides a fixed reference point to which the table can always return. Refer to page B78 for Limit and Home switch assembly details.

Linear Encoders

This option mounts to the inside of the table (*note aperture is reduced by approximately 1 inch*) and is used to give direct positional feedback of the carriage. Imperial resolution of 0.0001 inch and metric resolutions of 0.001 mm are available. Refer to page B80 for linear encoder details.

300000AT

315102AT	318121AT	318122AT	324161AT	324162AT	330241AT	330242AT
10 x 10 (250 x 250)	12 (300)	12 x 12 (300 x 300)	16 (400)	16 x 16 (400 x 400)	24 (600)	24 x 24 (600 x 600)
2.0 (50) 0.8 (20)	2.4 (61) 0.96 (24)	2.4 (61) 0.96 (24)	3.2 (81) 1.3 (33)	3.2 (81) 1.3 (33)	4.8 (122) 1.9 (49)	4.8 (122) 1.9 (49)
±1 (±25) ±0.05 (±1,3)	±1 (±25) ±0.05 (±1,3)	±1 (±25) ±0.05 (±1,3)	±1 (±25) ±0.05 (±1,3)	±1 (±25) ±0.05 (±1,3)	±1 (±25) ±0.05 (±1,3)	±1 (±25) ±0.05 (±1,3)
5 (127) 2 (51)	6 (152) 2.4 (61)	6 (152) 2.4 (61)	8 (203) 3.2 (81)	8 (203) 3.2 (81)	12 (305) 4.8 (122)	12 (305) 4.8 (122)
5 (127) 2 (51)	6 (152) 2.4 (61)	6 (152) 2.4 (61)	8 (203) 3.2 (81)	8 (203) 3.2 (81)	12 (305) 4.8 (122)	12 (305) 4.8 (122)
15 25	15 25	15 25	15 25	15 25	15 25	15 25
24 (600) 48 (1200)	24 (600) 48 (1200)	24 (600) 48 (1200)	24 (600) 48 (1200)	24 (600) 48 (1200)	24 (600) 48 (1200)	24 (600) 48 (1200)
50 75	50 75	50 75	50 75	50 75	50 75	50 75
210 (95) 105 (47)	300 (136) 150 (68)	260 (118) 130 (59)	370 (168) 185 (84)	310 (141) 155 (70)	440 (200) 220 (100)	380 (172) 119 (86)
25 (11,3) 55 (24,9)	25 (11,3) 55 (24,9)	25 (11,3) 55 (24,9)	25 (11,3) 55 (24,9)	25 (11,3) 55 (24,9)	25 (11,3) 55 (24,9)	25 (11,3) 55 (24,9)
— —	2.028 (1,46)	— —	2.60 (1,87)	— —	3.43 (2,47)	— —
15 0,106 16.5 (0,117)	15 0,106 16.5 (0,117)	15 0,106 16.5 (0,117)	15 0,106 16.5 (0,117)	15 0,106 16.5 (0,117)	15 0,106 16.5 (0,117)	15 0,106 16.5 (0,117)
30	30	30	30	30	30	30
0.003	0.003	0.003	0.003	0.003	0.003	0.003
72 (32,8)	43 (19,6)	86 (39)	57.8 (26,2)	115.6 (52,4)	72.3 (32,8)	144.6 (65,6)
60 30	— —	60 30	— —	60 30	— —	60 30

300000AT Series

300000AT Series

Order Example

How to Order

- Model Series**
- Width/Travel** Width Travel
- 10 in 250 mm 6 in 150 mm
- 15 in 375 mm 8 in 200 mm
- 15 in 375 mm 10 in 250 mm
- 18 in 450 mm 12 in 300 mm
- 24 in 600 mm 16 in 400 mm
- 33 in 825 mm 24 in 600 mm

- Number of Axes**
- One Axis
- Two Axis

- Table Style**

- Mounting**
- Imperial
- Metric

- Grade**
- Standard Grade
- Precision Grade

- Drive Screw**
- 0.02 in Lead (50 Pitch)
- 0.10 in Lead (10 Pitch)
- 0.20 in Lead (5 Pitch)
- 1.0 mm Lead
- 2.0 mm Lead
- 5.0 mm Lead

- Limit/Home**
- No Limit/Home Switches
- Magnetic Limit/Home Switches
- Optical Limit/Home Switches

- Motor Coupling**
- No Coupling
- 0.25 in Bore, Helix, Aluminum
- 0.25 in Bore, Helix, Stainless Steel
- 0.25 in Bore, Bellows, required for Precision Grade
- 0.375 in Bore, Helix, Aluminum
- 0.375 in Bore, Helix, Stainless Steel
- 0.375 in Bore, Bellows, required for Precision Grade

- Motor Mount**
- 23 Frame Size
- 34 Frame Size [Not available in 31006 model]

- Encoder**
- No Encoder
- Linear Encoder, Imperial, 0.0001 in Resolution
- Linear Encoder, Metric 1.0 μm Resolution

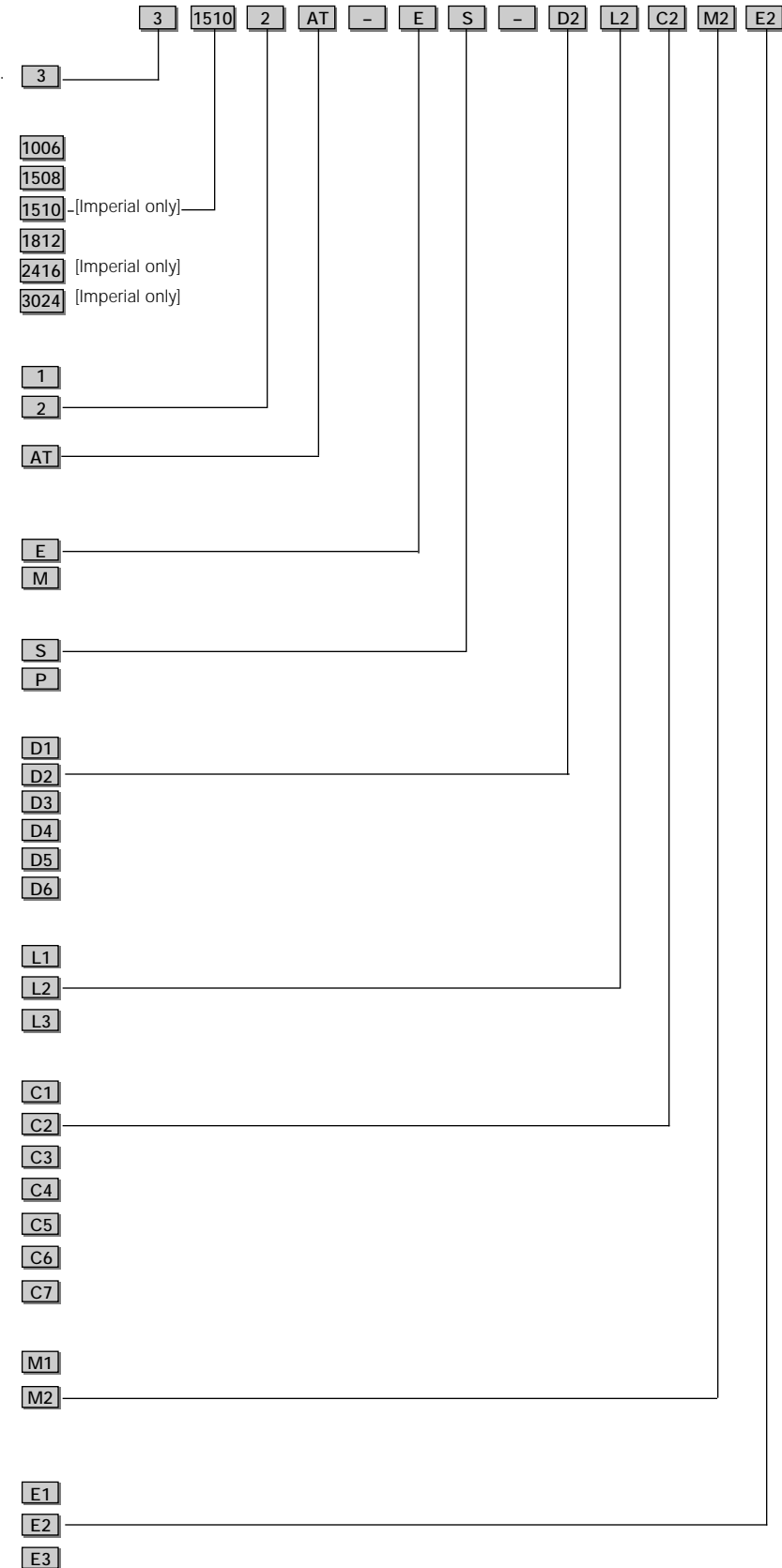

Linear Open Frame Tables

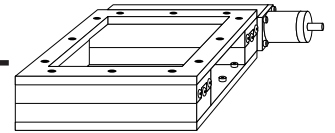

310062AT Dimensions

in (mm)

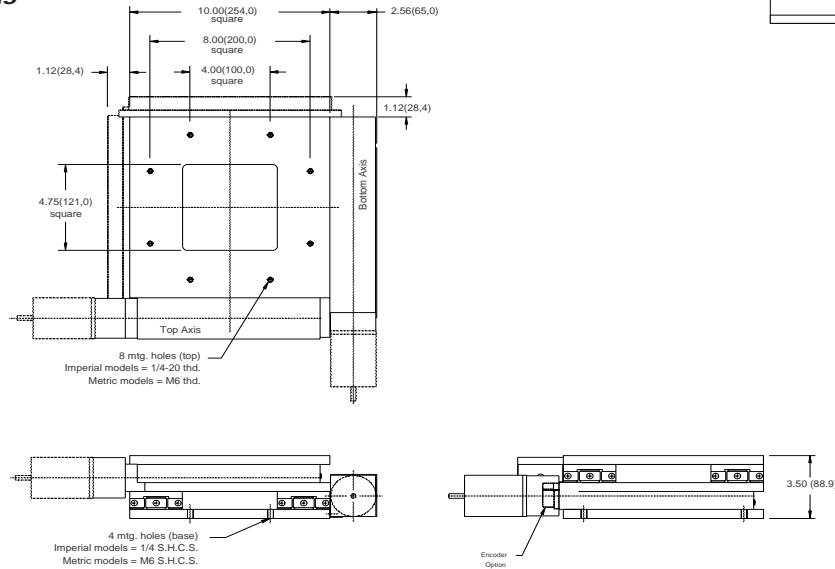

Two Axis X-Y Table

315000AT/318000AT Dimensions

in (mm)

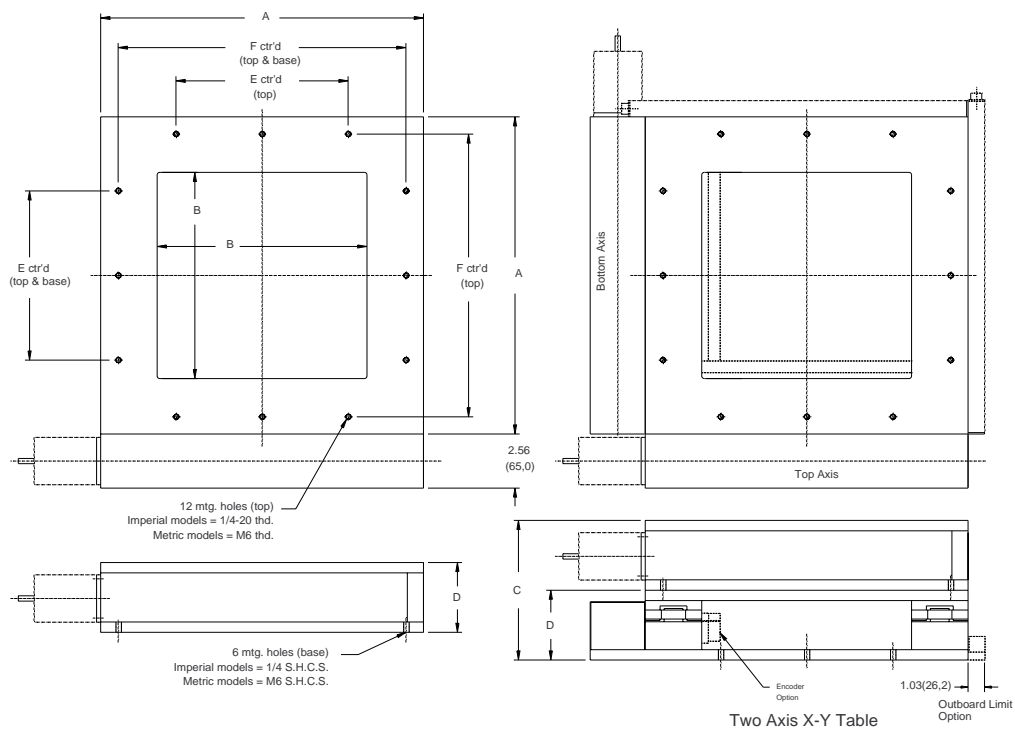

Two Axis X-Y Table

		Width	Opening	Height		Mounting	
Model	A	B	C	X Axis	D	E	F
Imperial	315000AT-E	15 in	9.75 in	6.5 in	3.25 in	8 in	13.38 in
	318000AT-E	18 in	12.75 in	6.5 in	3.25 in	10 in	16.38 in
Metric	315000AT-M	381 mm	248 mm	165,1 mm	82,5 mm	200 mm	325 mm
	318000AT-M	457 mm	324 mm	165,1 mm	82,5 mm	250 mm	400 mm

300000AT

30000AT Series

324000/330240AT Series Dimensions

in (mm)

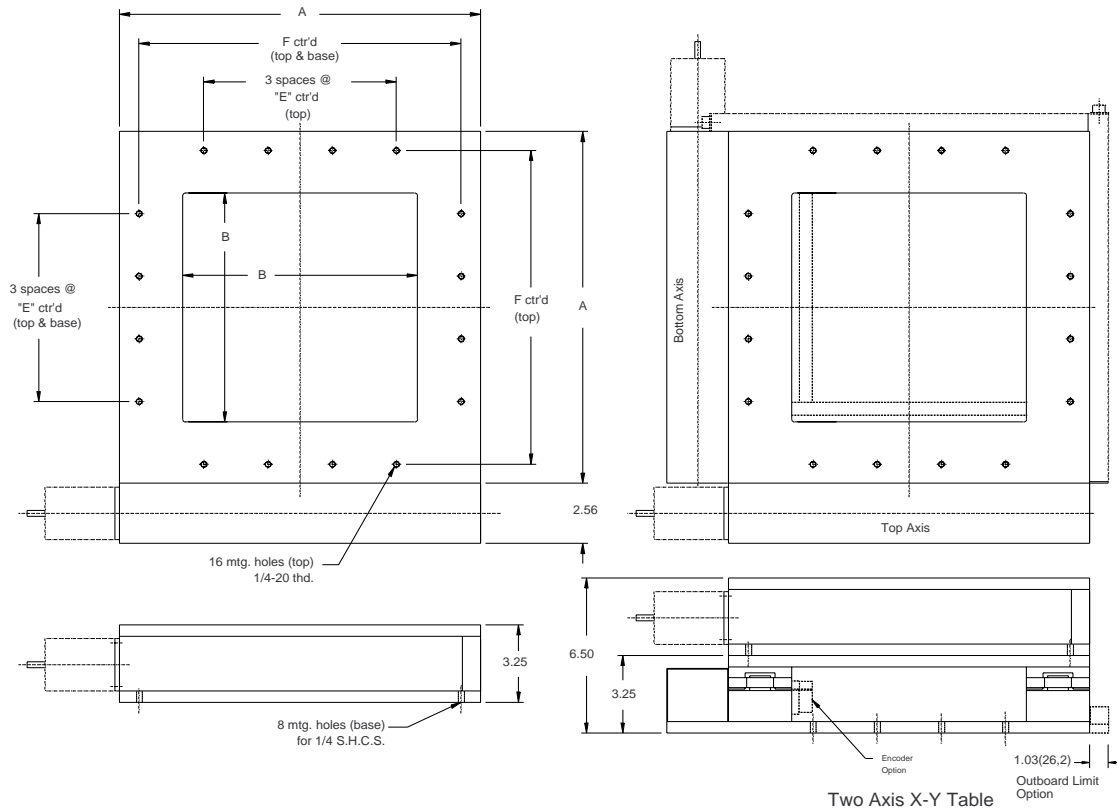

	Model	Width A	Opening B	Height		Mounting	
				X-Y Axis C	X Axis D	E	F
Imperial	324000AT-E	24 in	18.75 in	6.50 in	3.25 in	15 in	22.38 in
Imperial	330000AT-E	30 in	24.75 in	6.50 in	3.25 in	22.5 in	28.38 in

Linear Open Frame Tables

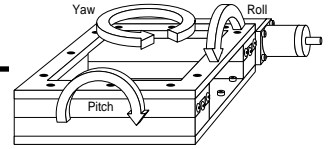

Yaw, Pitch and Roll

Yaw **Pitch** **Roll**

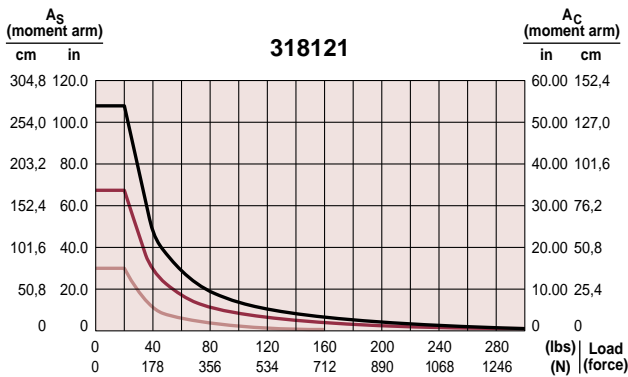
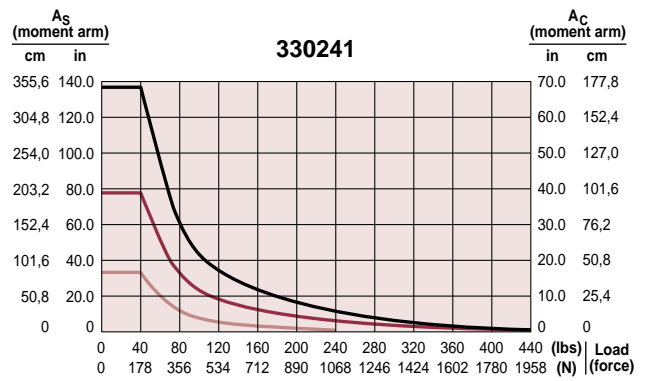
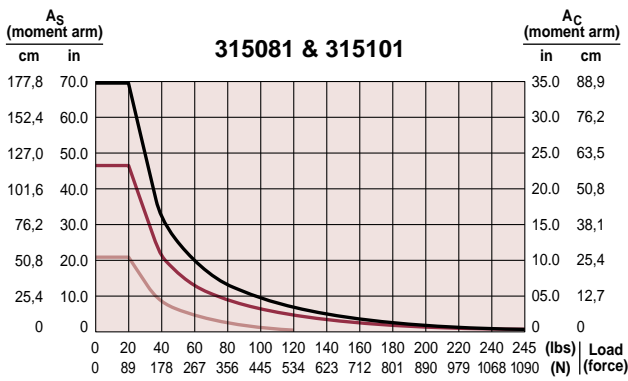
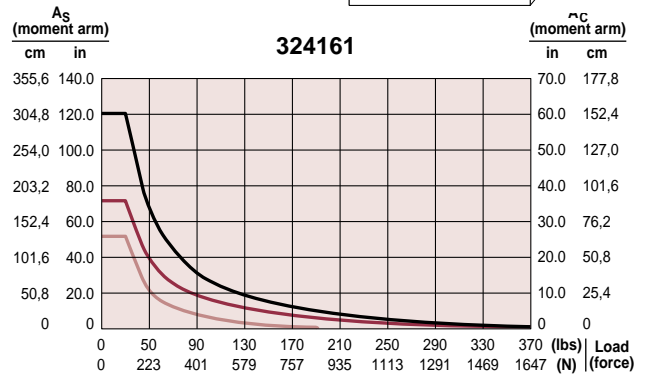
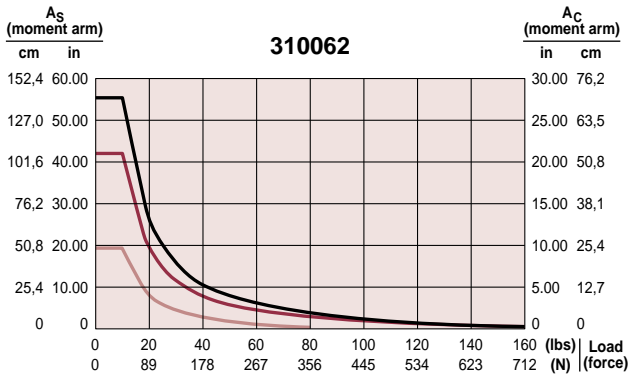

300000AT