

105000BT & 106000BT/CT Series

Ball Bearing and Cross Roller Bearing Tables

Designed for high accuracy and extremely smooth motion, 100000 series tables are ideal for light to moderate duty cycle applications such as automated testing, quality control gauging, laser positioning or fiber optics alignment. The BT style table is equipped with ball bearing linear ways which provide extremely smooth motion and excellent straight line and flatness accuracy. If higher load capacity is required, the CT style tables (not available in 105000 series) incorporate cross roller linear bearings which provide twice the load capacity.

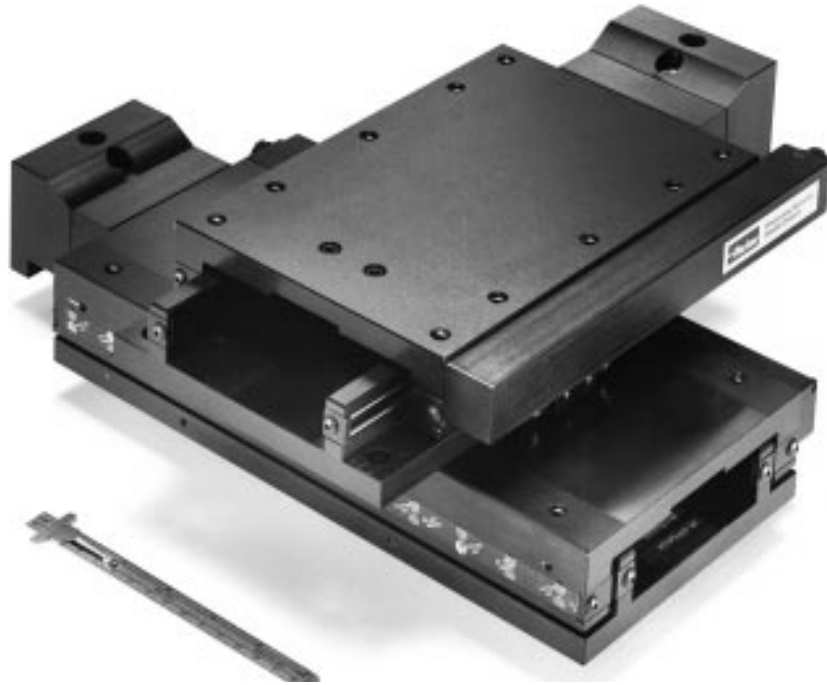

Specifications

		105002BT	
Travel – inches (mm)		2	(50)
Positional Accuracy/Travel – x 0.001 in (µm) Over Total Table Travel	Standard Grade	0.4	(10,2)
	Precision Grade	0.32	(8,1)
Positional Repeatability – x 0.001 in (µm)	Standard Grade	±1	(±25)
	Precision Grade	±0.05	(±1,3)
Straight Line Accuracy – x 0.001 in (µm) Over Total Table Travel	Standard Grade	0.4	(10,2)
	Precision Grade	0.16	(±4,1)
Flatness Accuracy/Travel – x 0.001 in (µm) Over Total Table Travel	Standard Grade	0.4	(10,2)
	Precision Grade	0.16	(4,1)
Max Screw Speed – rps	Standard Grade	15	
	Precision Grade	25	
Max Acceleration – in/sec ² (mm/sec ²)	Standard Grade	24	(600)
	Precision Grade	48	(1200)
Duty Cycle – % of motion to dwell per move	Standard Grade	50	
	Precision Grade	75	
Axial Loading – lbs (kgf)	Standard Grade*	10	(4,5)
	Precision Grade	28	(12,7)
Direct Loading*** – lbs (kgf)	Normal, Ball Bearing	60	(27,2)
	Inverted, Ball Bearing	30	(13,6)
	Normal, Cross Roller Bearing	—	—
	Inverted, Cross Roller Bearing	—	—
Input Inertia** – 10 ⁻³ oz-in-sec ² (10 ⁻⁶ kg-m-sec ²)	Ball Bearing	0.31	(0,22)
	Cross Roller Bearing	—	—
Max Running Torque – oz-in (N-m)		15	(0,106)
Max Breakaway Torque – oz-in (N-m)		16.5	(0,117)
Drive Screw Efficiency—Standard & Precision Leadscrew – %		30	
Coefficient of Linear Bearing Friction	Ball Bearing	0.003	
	Cross Roller Bearing	—	
Table Weight – lbs (kgf)	Ball Bearing	4.0	(1,81)
	Cross Roller Bearing	—	—

* Not recommended for vertical applications

** Based on 5 pitch (0.2 inch lead) leadscrew

*** Refer to page B30 for moment load graphs

Ball Bearing/Cross Roller Linear Tables

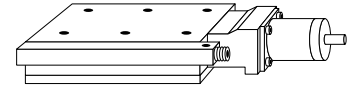

Standard or Precision Grades

These tables are available in both standard as well as precision grades. The standard grade is equipped with a ground lead screw and a composite nut, while the precision grade is equipped with a precision ground lead screw and phosphorus bronze nut.

Wide Selection of Lead Screws

Both the BT and CT style tables are available with a wide range of Daedal manufactured drive screws with leads in both Imperial and metric leads to match your resolution and speed requirements. Additionally, a special solid acme nut is available for use in vertical applications.

Quality Design in Imperial or Metric Mounting

Table housings are constructed of high quality aluminum alloy and are protected with a black anodized surface finish. The top and bottom mounting surfaces are precision ground to assure flatness and all mounting holes are fitted with locking steel threaded inserts to prevent mounting bolts from working loose. The BT series linear bearings are made of 440C stainless steel; the CT style uses steel cross roller bearings.

The BT style table is available in either Imperial or metric mounting. The CT (cross roller) style is only available in Imperial mounting.

Options:

Motor Couplings

A wide range of coupling styles and bores are available to match your motor requirements. Bellows-style couplings are required for all precision grade tables and have the lowest radial wind-up, while the aluminum and stainless steel helix couplers offer good wind-up characteristics and high durability at a lower cost.

Motor Mounts

The motor mount is designed for an industry standard NEMA 23 motor flange with shaft lengths between 0.65 and 0.85 inches.

Limit and Home Switches

All styles of the 100000 series can be equipped with either mechanical reed switch or optical sensor type limit

and home switch assemblies. The limit switches provide a signal when the table is approaching its end of travel which is used to command the motor to stop. The Home sensor provides a fixed reference point to which the table can always return. Refer to page B78 for Limit and Home switch details.

Linear Encoders

This option mounts to the side of the table and is used to give direct positional feedback of the carriage. Imperial resolution of 0.0001 inch and metric resolution of 0.001 mm are available. Refer to page B80 for linear encoder details.

100000BT/CT

106004BT/CT		106006BT/CT		106008BT/CT		106010BT/CT		106012BT/CT	
4	(100)	6	(150)	8	(200)	10	(250)	12	(300)
0.8	(20)	1.2	(30)	1.6	(40)	2.0	(50)	2.4	(60)
0.32	(8)	0.48	(12)	0.64	(16)	0.8	(20)	0.96	(24)
±1	(±25)	±1	(±25)	±1	(±25)	±1	(±25)	±1	(±25)
±0.05	(±1,3)	±0.05	(±1,3)	±0.05	(±1,3)	±0.05	(±1,3)	±0.05	(±1,3)
0.8	(20)	1.2	(30)	1.6	(40)	2.0	(50)	2.4	(60)
0.32	(8)	0.48	(12)	0.6	(16)	0.6	(16)	0.6	(16)
0.8	(20)	1.2	(30)	1.6	(40)	2.0	(50)	2.4	(60)
0.32	(8)	0.48	(12)	0.6	(16)	0.6	(16)	0.6	(16)
15		15		15		15		15	
25		25		25		25		25	
24	(600)	24	(600)	24	(600)	24	(600)	24	(600)
48	(1200)	48	(1200)	48	(1200)	48	(1200)	48	(1200)
50		50		50		50		50	
75		75		75		75		75	
25	(11,3)	25	(11,3)	25	(11,3)	25	(11,3)	25	(11,3)
55	(24,9)	55	(24,9)	55	(24,9)	55	(24,9)	55	(24,9)
100	(45)	110	(50)	120	(54)	130	(59)	140	(64)
50	(23)	55	(25)	60	(27)	65	(29)	70	(32)
200	(90)	220	(100)	240	(108)	260	(118)	280	(128)
100	(45)	110	(50)	120	(54)	130	(59)	140	(64)
0.767	(5,41)	0.978	(6,91)	1.175	(8,30)	1.368	(0,966)	1.561	(11,02)
0.791	(5,59)	1.015	(7,17)	1.224	(8,64)	1.429	(10,09)	1.634	(11,54)
15	(0,106)	15	(0,106)	15	(0,106)	15	(0,106)	15	(0,106)
16.5	(0,117)	16.5	(0,117)	16.5	(0,117)	16.5	(0,117)	16.5	(0,117)
30		30		30		30		30	
0.003		0.003		0.003		0.003		0.003	
0.003		0.003		0.003		0.003		0.003	
7.2	(3,3)	10.2	(4,6)	13.2	(6,0)	16.0	(7,3)	19.1	(8,7)
7.6	(3,4)	10.5	(4,8)	13.6	(6,2)	16.7	(7,6)	19.8	(9,0)

Ball Bearing/Cross Roller Linear Tables

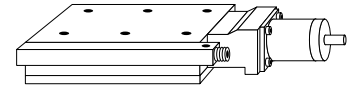

105002BT Dimensions

in (mm)

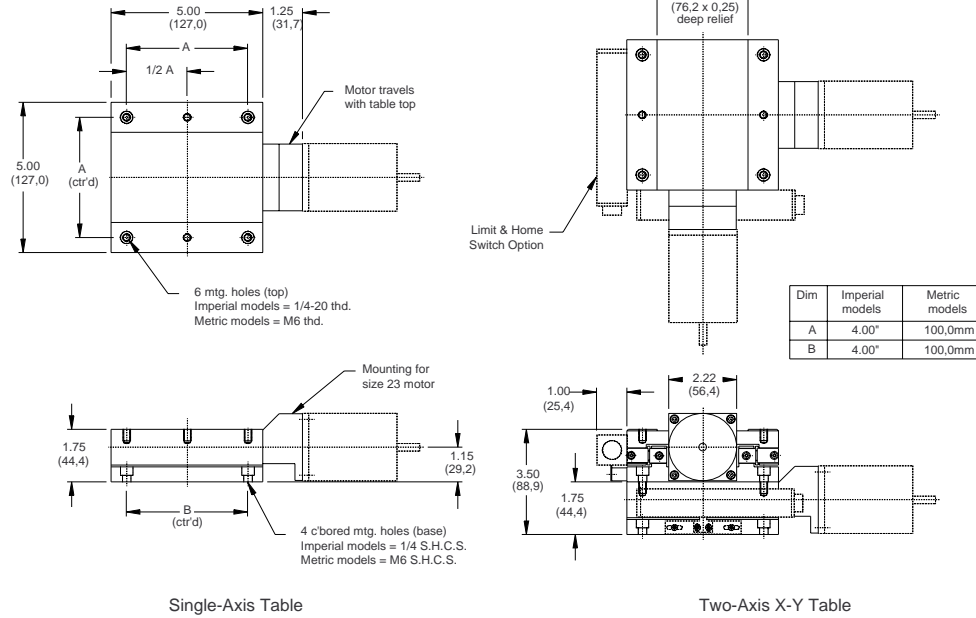

106000BT/CT Series Dimensions

in (mm)

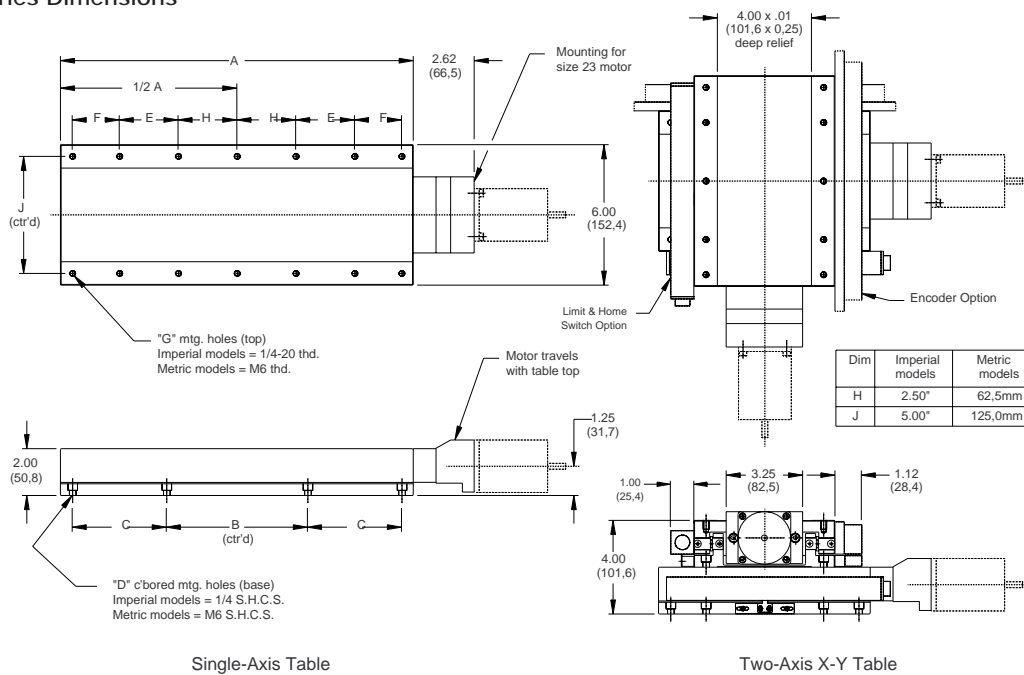

	Model	Travel	A	B	C	Quantity	D	E	F	Quantity	G
Imperial	106004	4 in	6 in	5 in	—	4	—	—	—	6	
	106006	6 in	9 in	5 in	1.5 in	8	1.5 in	—	—	10	
	106008	8 in	12 in	5 in	3 in	8	2.5 in	—	—	10	
	106010	10 in	15 in	6 in	4 in	8	2.5 in	—	2 in	14	
	106012	12 in	18 in	7 in	5 in	8	5 in	1 in	—	14	
Metric	106004M	100 mm	152,4 mm	125,0 mm	—	4	—	—	—	6	
	106004M	150 mm	228,6 mm	125,0 mm	37,5 mm	8	37,5 mm	—	—	10	
	106004M	200 mm	304,8 mm	125,0 mm	75,0 mm	8	62,5 mm	—	—	10	
	106004M	250 mm	381,0 mm	150,0 mm	100,0 mm	8	62,5 mm	50,0 mm	—	14	
	106004M	300 mm	457,2 mm	175,0 mm	125,0 mm	8	125,0 mm	25,0 mm	—	14	

100000BT/CT

105000BT & 106000BT/CT Series

Yaw, Pitch and Roll

Yaw Pitch Roll

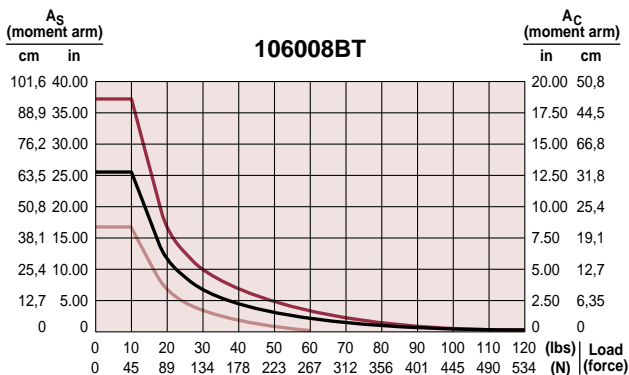
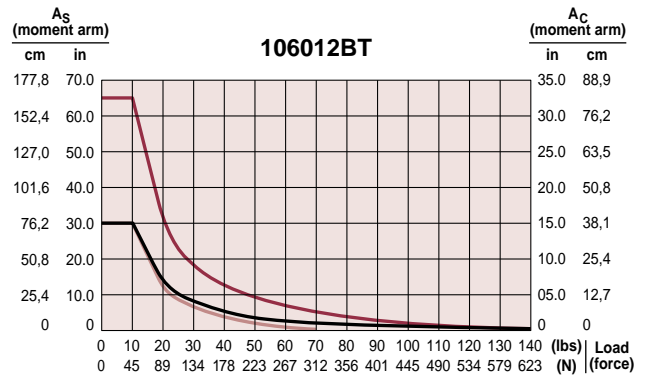
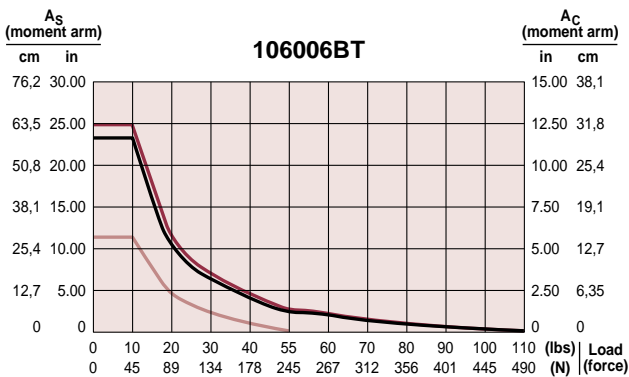
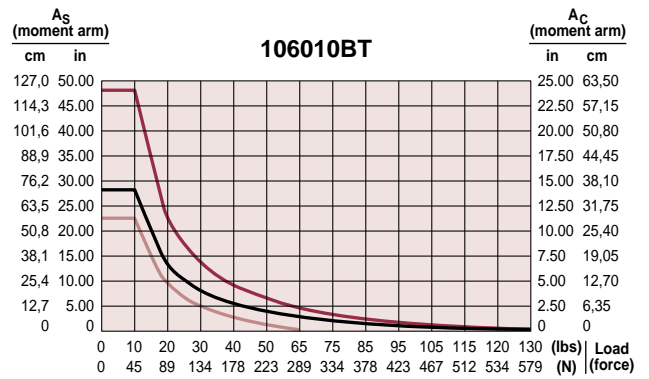
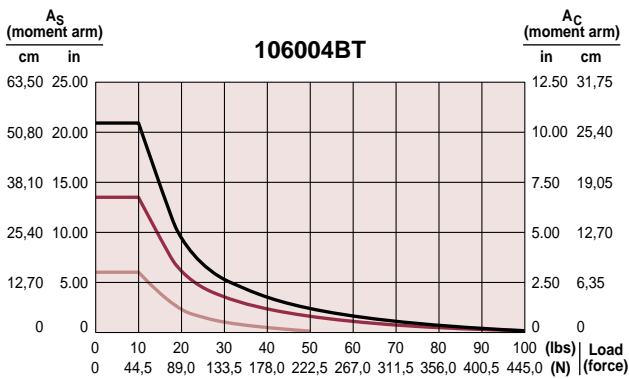
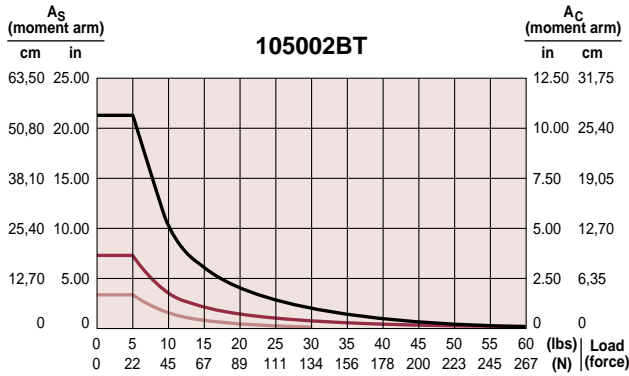

Ball Bearing/Cross Roller Linear Tables

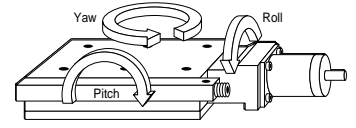

Yaw, Pitch and Roll

Yaw Pitch Roll

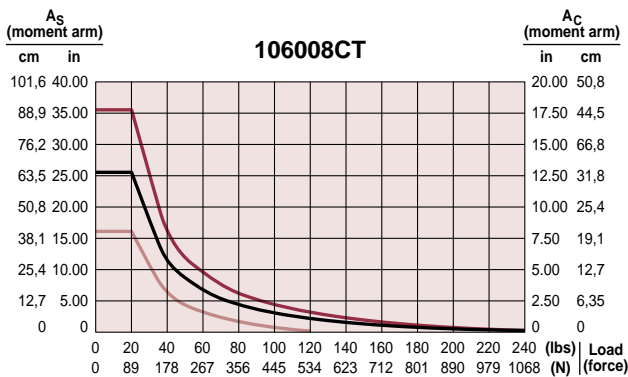
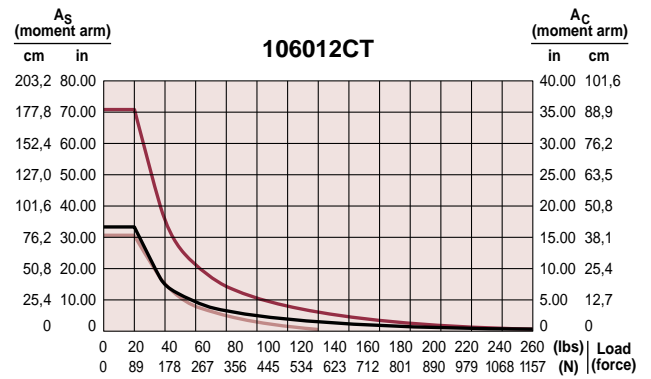
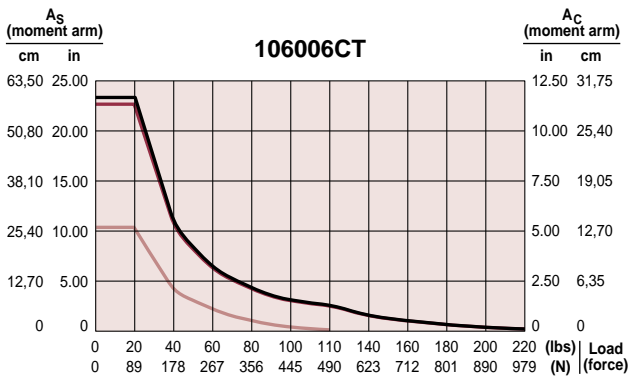
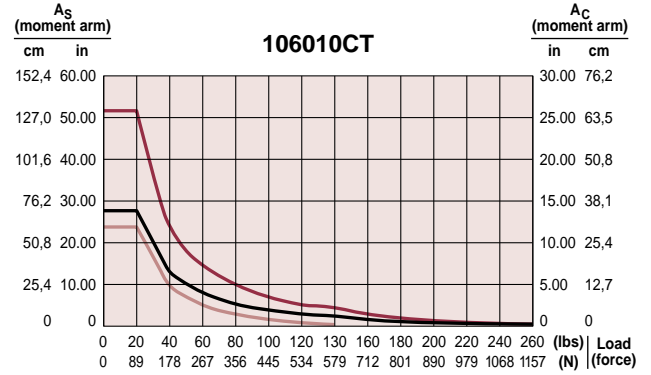
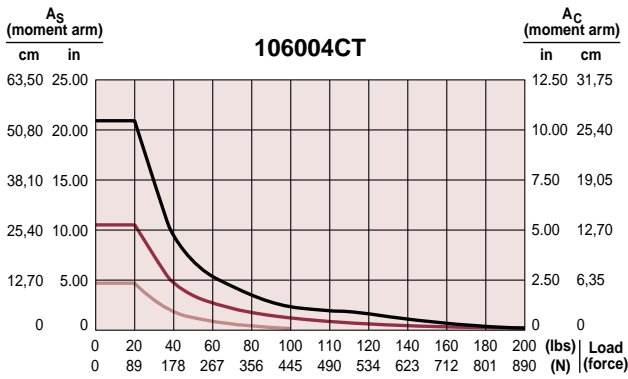

100000BT/CT